



Box 70396 | 10724 STOCKHOLM | SWEDEN  
Klarabergsviadukten 70  
Tel +46 (0)8-103070 | Fax +46 (0)8-103060  
info@crealux.se | www.crealux.se



Le lampade di **Rotaliana** sono espressione di una originale atmosfera produttiva che unisce tradizione e innovazione, radici antiche e pensiero contemporaneo.

In tutti i prodotti della collezione è possibile cogliere il senso delle più attuali tendenze estetiche contemporanee: tendenze che uniscono, quasi come un ponte immaginario, le persone ai prodotti, le aziende al pubblico.

Le lampade di Rotaliana interpretano il desiderio di bello ormai acquisito da grande parte delle persone, orientate ad un bello che non si ferma solo alla superficie, alla parte visiva, ma che si deve riempire di contenuti di qualità.

Un bello, quindi, che è anche ben fatto e che interpreta le competenze delle persone, dei progettisti e dell'azienda.

Un bello che oltrepassa l'involucro per arrivare a definire oggetti con un'anima, che appagano il cuore e non solo gli occhi.

*Rotaliana lamps are expressions of an original production environment, combining tradition and innovation, traditional roots and modern thinking.*

*In each of its new products, we can gain a strong sense of the aesthetic tendencies that characterize the contemporary scene and, almost like an imaginary bridge, link people with products, companies with the public. Rotaliana lamps are projects which interpret the search for beauty - which is now a taste acquired by a large part of the population - but with a preference for a beauty not restricted just to the outer form, the visible impact, but which must be filled with a quality content. A beauty, in fact, which is also well made, which illustrates the capabilities of the personnel and designers of the company. A beauty that goes beyond the externals and reaches out to define objects with an inner spirit that satisfy the earth and not just the eye.*



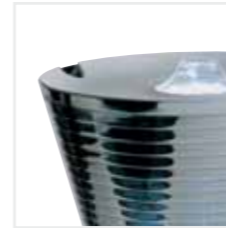

**MultiPot**

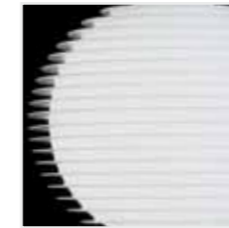

**Flow**



**BPL**

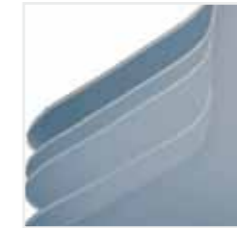

**Cloud**



**Honey**



**EyeBall**



**Ipe**



**Lisca**



**Drink**

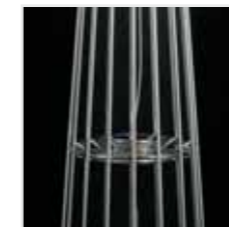

**Lightwire**



**Goccia**



**Conca**



**Luxy**



**Officina**



**Artica**

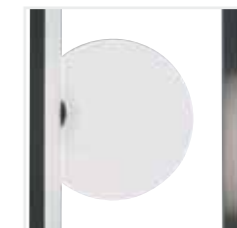

**Bubble**



Box 70396 | 10724 STOCKHOLM | SWEDEN  
Klarabergsviadukten 70  
Tel +46 (0)8-103070 | Fax +46 (0)8-103060  
info@crealux.se | www.crealux.se



**Designers**

# MultiPot

design Dante Donegani & Giovanni Lauda, 2005



MultiPot appartiene ad una nuova generazione di oggetti luminosi: è il primo prodotto di Rotaliana che associa la luce ad altre prestazioni. È una lampada ibrida e multifunzionale in cui convergono più funzioni: una luce d'atmosfera a LED, una presa multipla e la raccolta dei cavi in eccesso nel contenitore inferiore a forma di vaso. MultiPot realizza nuove condizioni di confort in casa e negli ambienti di lavoro, intrecciando vecchi rituali d'uso (ad es. riporre le chiavi o altri oggetti personali in un contenitore vuoto tasche) e nuovi comportamenti (ad es. l'utilizzo sempre maggiore di apparecchi multimediali a ricarica, l'uso del computer in casa, la trasformazione del televisore in "home theatre"). L'aspetto familiare, la performance luminosa e le finiture traslucide (che filtrano la luce mascherando i cavi elettrici), danno al MultiPot una immagine tecnica ma elegante.

MultiPot belongs to a new generation of lighting objects and is the first of our Rotaliana products to combine lighting with other functions. This hybrid, multifunctional lamp combines an LED ambient light with a multisolet, along with a space to tidy cables in the lamp's vase. MultiPot provides new comfort levels, both in the home and at work by catering for both old and new requirements: our habit of emptying keys and other personal items, from pockets into containers, with new requirements to manage our increased use of rechargeable multimedia equipment, home computers and the transformation of televisions into home theatres. With its familiar looks, lighting function and translucent finish (to filter the light while masking the electric cables), the MultiPot is a picture of elegant functionality.

#### Multipresa a 5 uscite

- Interruttore integrato acceso/spento, con indicatore luminoso "In tensione"
- 5 prese adatte a eurospine 2P 2,5A, spine 2P e 2P+T 10A standard italiano, spine 2P+T 16 A standart tedesco
- Lunghezza del cavo: 1,9m con spina Schuko
- Prese girate a 60° gradi
- Cavo: H05 VV-F sezione 1 mm<sup>2</sup>
- Conforme allo standard IEC 884-1
- Potenza erogabile max 2000W

#### Lampada

Lampada a LED con doppia emissione, verso l'alto e verso il basso.  
Interruttore per accensione e spegnimento.  
Consumo 4,2Watt - Vita di 60.000 ore.

#### 5-way Multisolet

- Built-in on/off switch with illuminated indicator of "Power On"
- 5-way multisolet for 2P 2.5A europlugs; 2P and 2P plugs +T 10A Italian standard, and 2P+T 16A German standard



Box 703 lamp 10724 STOCKHOLM | SWEDEN  
Klaraberget 70  
Tel +46 (0)8-103070 | Fax +46 (0)8-103060  
info@crealux.se | www.crealux.se

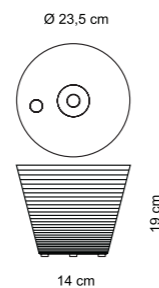



**CREALUX**

Box 100, SE-102 11 STOKHOLM, SWEDEN  
Tel: +46 (0)8 103070 Fax: +46 (0)8 103060  
www.crealux.se





 CREALUX

Box 70396 | 10724 STOCKHOLM | SWEDEN  
Klarabergsviadukten 70  
Tel +46 (0)8-103070 | Fax +46 (0)8-103060  
info@crealux.se | www.crealux.se

# Flow

design Dante Donegani & Giovanni Lauda, 2005

Famiglia composta da lampade da terra, tavolo, soffitto e sospensione. Diffusore sferoidale in policarbonato opalino. Il volume del diffusore si scompone visivamente in una serie di anelli concentrici sovrapposti, che intercettano e propagano la luce.

Cavo di alimentazione trasparente.

Rosone in policarbonato stampato ad iniezione. Nelle versioni da terra e da tavolo il diffusore viene montato su un gambo in metallo e le lampade sono provviste di touch dimmer.

*A family including floor, table, ceiling and suspension lamps. Spheroidal diffuser made of transparent polycarbonate. The volume of the diffuser is visually decomposed into a serie of overlapped concentric rings, which intercept and propagate the light.*

*Transparent power cable.*

*Injection moulded polycarbonate wall rose.*

*For the floor and table version the diffuser is mounted on a metal stem and the lamp is equipped with a touch dimmer.*

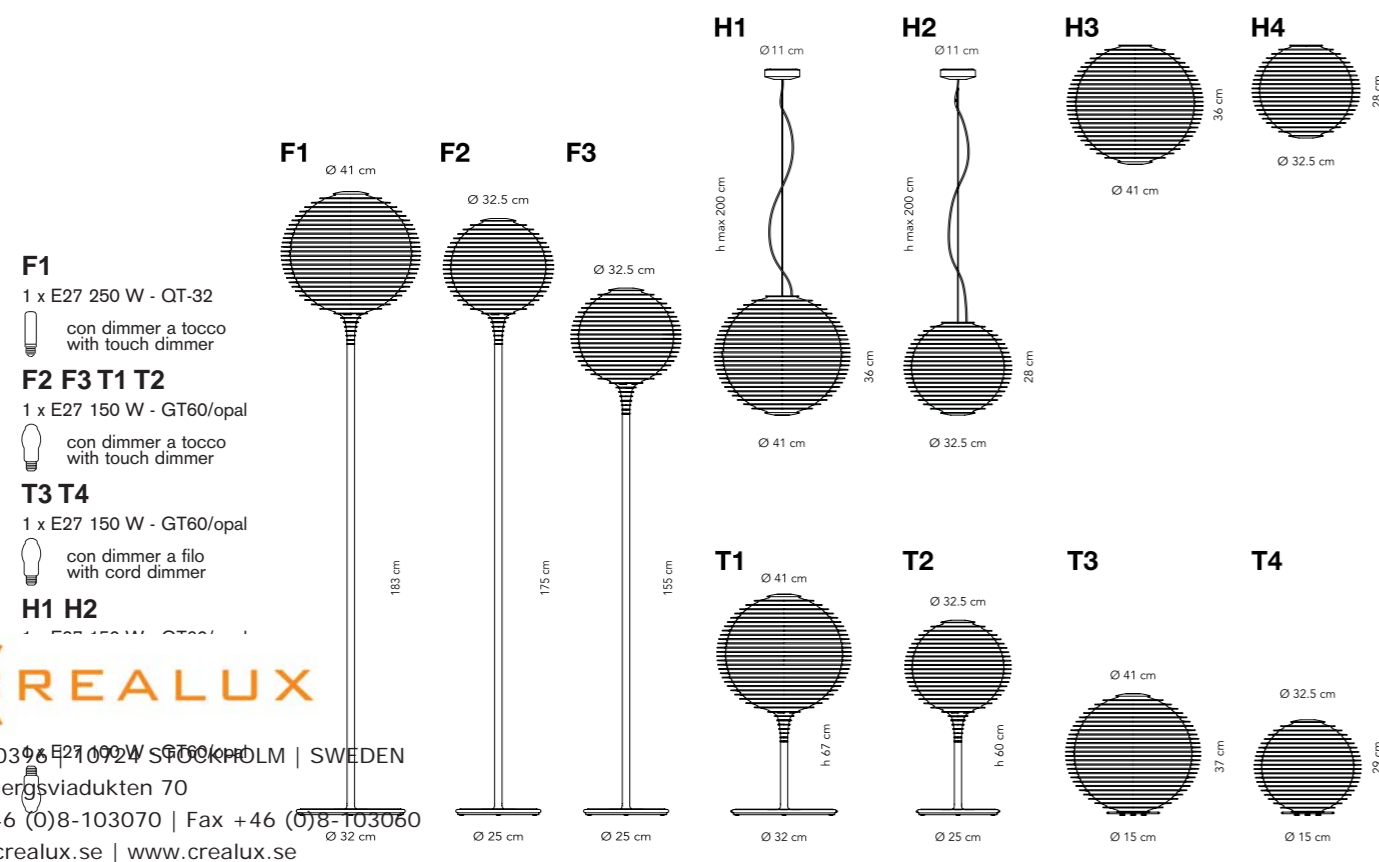

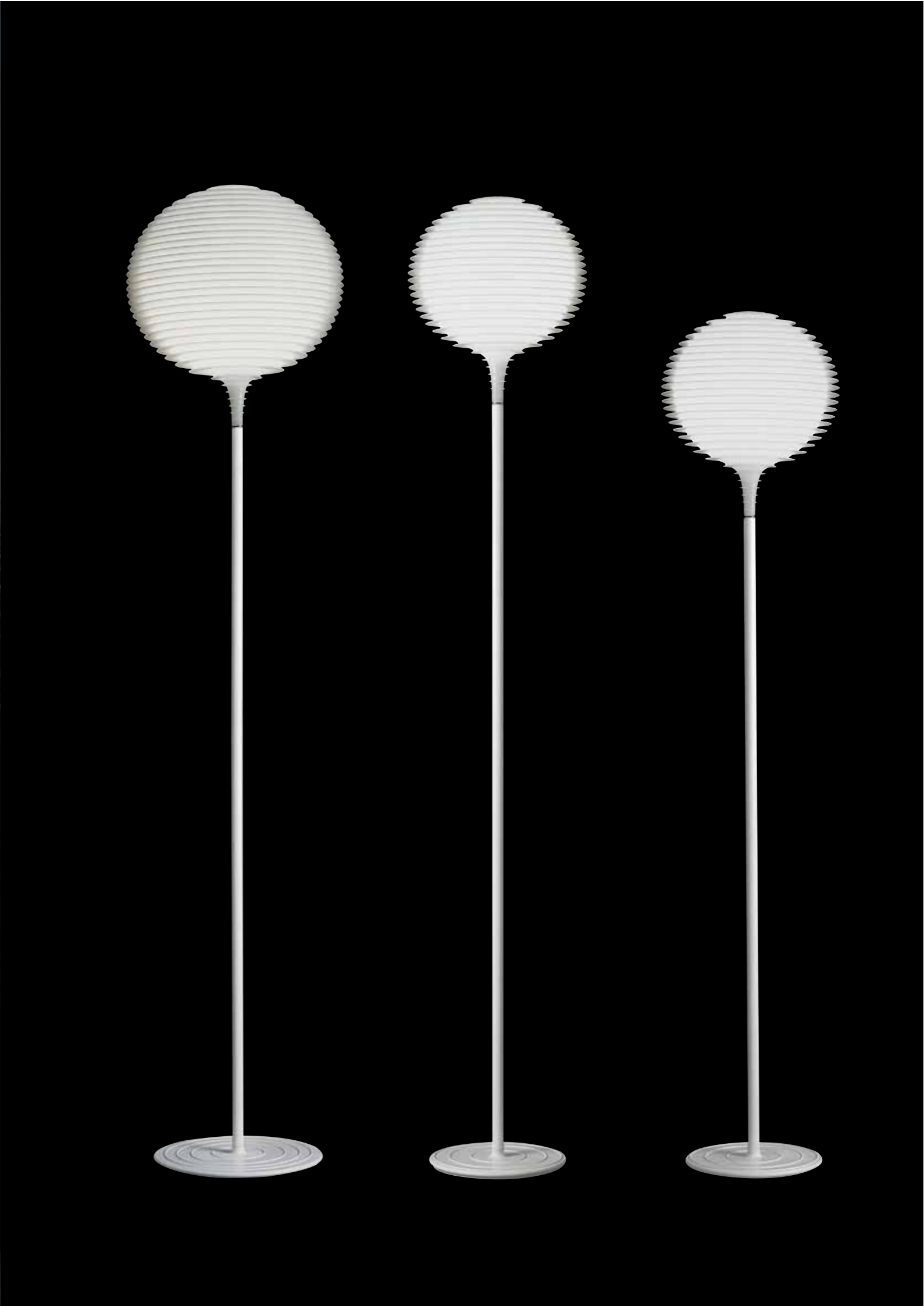

Box 70396 | 10724 STOCKHOLM | SWEDEN  
Klarabergsviadukten 70  
Tel +46 (0)8-103070 | Fax +46 (0)8-103060  
info@crealux.se | www.crealux.se





Box 70396 | 10724 STOCKHOLM | SWEDEN  
Klarabergsviadukten 70  
Tel: +46 (0)8 303070 | Fax: +46 (0)8 303071  
info@crealux.se | www.crealux.se



Box 70396 | 10724 STOCKHOLM | SWEDEN  
Klarabergsviadukten 70  
Tel +46 (0)8-103070 | Fax +46 (0)8-103060  
info@crealux.se | www.crealux.se



Box 70396 | 10724 STOCKHOLM | SWEDEN  
Klarabergsviadukten 70  
Tel +46 (0)8-103070 | Fax +46 (0)8-103060  
info@crealux.se | www.crealux.se

# BPL

design Camilla Diedrich, 2005

Lampada a sospensione a luce diffusa.  
Prodotta in due differenti dimensioni, unisce tecniche artigianali a standard industriali. Il globo bianco è realizzato utilizzando un tessuto poliestere bianco "Creation Baumann" lavorato a mano. Il tessuto, annodato ai calchi in legno e quindi deformato in un forno a vapore, diventa tridimensionale, a bolle: un motivo decorativo, a rilievo, che diffonde e sfaccetta la luce.  
La lampada ha vinto "The Excellent Swedish Design Award".

*Hanging lamps.  
Globe realized with hand-made white polyester woven "Creation Baumann".  
Internal structure in iron, electrostatic painted.  
The woven, knotted to the wooden casts and then deformed in a steam oven, becomes three-dimensional, with little bubbles: a decorative design, embossed, which emanates and sfacets the light.  
The lamp has won "The Excellent Swedish Design Award".*

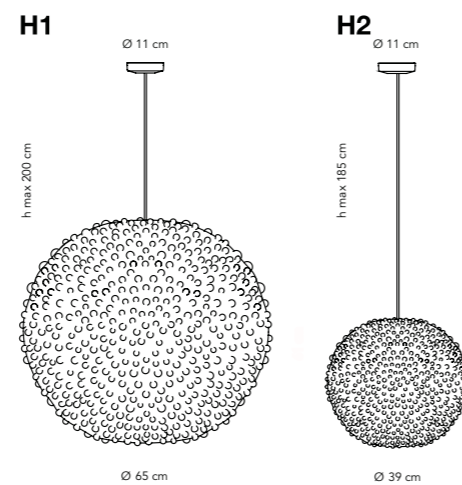

**H1**  
CREALUX

Box 70396 | 171 05 24-510 | STOCKHOLM | SWEDEN  
Klarabergsviadukten 70  
Tel +46 (0)8-103070 | Fax +46 (0)8-103060  
info@crealux.se | www.crealux.se



Box 20496, 10324 Stockholm, Sweden  
Märbergsvägen 70  
Tel +46 (0)8 103070 | Fax +46 (0)8 103060  
info@crealux.se | www.crealux.se

# Cloud

design Toyo Ito, 2004

E' una sospensione costruita sovrapponendo cinque sottili lastre di acrilico, tagliate al laser. La stratificazione delle lastre, la discontinuità della materia nei vuoti concentrici, la trasparenza del materiale plastico, il riferimento alla forma mutevole e all'inconsistenza materica delle nuvole, esprimono la ricerca di un nuovo modello di fisicità 'fluida'.

*A suspended unit, constructed by overlaying five thin layers of acrylic. The stratification of these layers, the breaks in continuity in the material building up the concentric spaces, the transparency of plastic material, and the reference to the changing shape and immateriality of clouds, all contribute towards the search for a new model of fluid substance.*

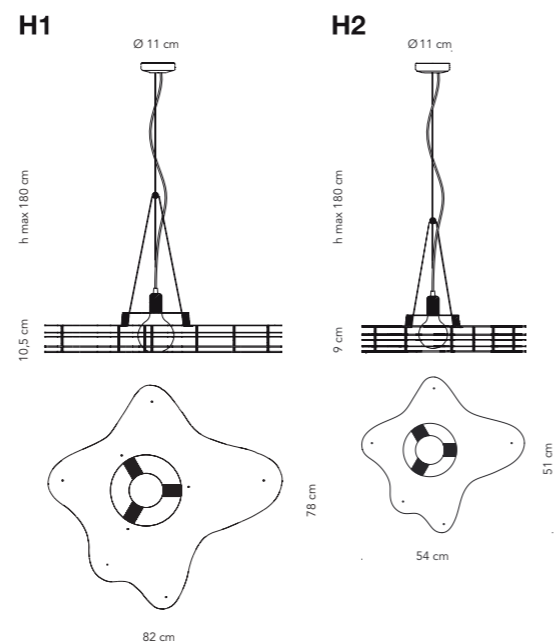

H1  
CREALUX

Box 70396 E-110924 STOCKHOLM | SWEDEN  
Klarabergsviadukten 70  
Tel +46 (0)8-103070 | Fax +46 (0)8-103060  
info@crealux.se | www.crealux.se



Box 70396 | 10724 STOCKHOLM | SWEDEN  
Klarabergsviadukten 70  
Tel +46 (0)8-103070 | Fax +46 (0)8-103060  
info@crealux.se | www.crealux.se

# Honey

design Dante Donegani & Giovanni Lauda, 2004

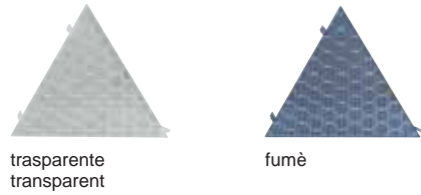

Famiglia composta da lampade da terra, tavolo e sospensioni. E' un sistema di lampade a luce diffusa, concepite come strutture modulari trasparenti, dalle dimensioni teoricamente infinite, come la "Endless Column" di Brancusi. La texture degli elementi triangolari, a nido d'ape e micro-prismatizzata, distribuisce il flusso luminoso all'interno dell'apparecchio. Il sistema comprende tre elementi di base, assemblati tra di loro a scatto (un triangolo/diffusore, un quadro/nervatura, un elemento di coronamento) e i supporti (la base, le gambe in tondino, l'attacco per la sospensione). L'operazione di montaggio delle lampade, molto semplice, a secco e senza utensili, è lasciata all'utente. Utilizzando le componenti del sistema si possono realizzare, nelle dimensioni desiderate, diversi modelli di lampade.

*This is a system of light elements built around diffused light, designed on a modular transparent structure, of theoretically unlimited extension, like "Brancusi's Endless" column. The texture of the triangular components, in a honey comb structure and micro-prismatic, directs the distribution of the light flow through the interior of the structure. The system is composed of three basic components, assembled together in a clip-on process (the elements are a triangle as diffuser, a square as frame, a crown as cover) and the supports (the base, the rod iron legs, and the fixture for the suspension). The assembly operations, which are extremely simple and require no additional tools, can be left to the user. By using the components available to the system, it is possible, within the required dimensions, to choose from several lamp alternatives.*

- F**  
1 x E27 150W - R95/20°  
con dimmer a pedale  
with foot dimmer
- TT1**  
1 x E27 100W - R95/20°  
con dimmer a filo  
with cord dimmer
- T2**  
1 x E27 100W - R95/20°

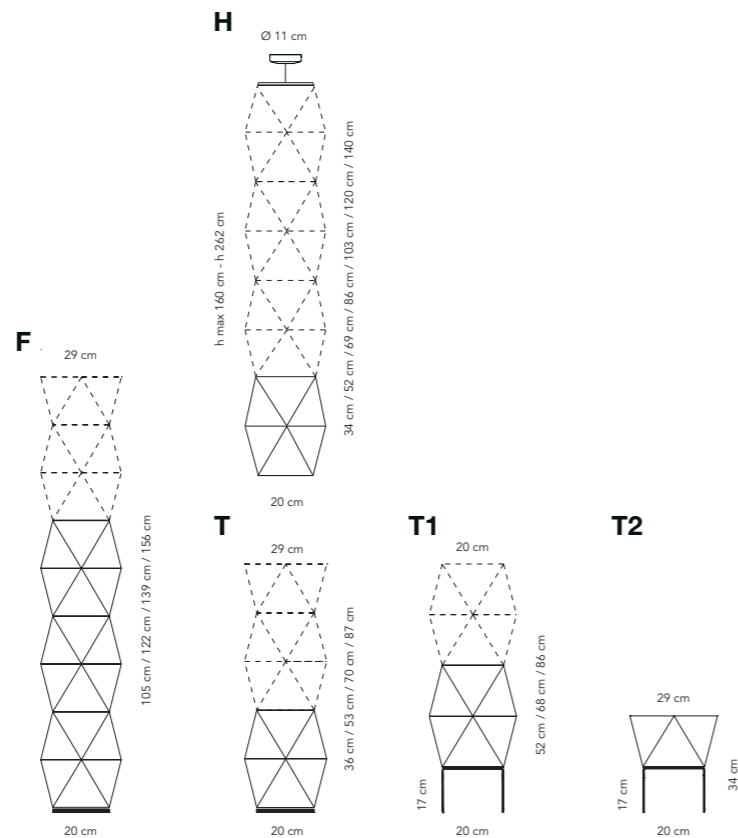

Box 70396, E27 150W - R95/20°  
Klarabergsviadukten 70  
Tel +46 (0)8-103070 | Fax +46 (0)8-103060  
info@crealux.se | www.crealux.se







CREALUX

Box 70396, SE-201 38 HÖLM | SWEDEN  
Klarabergsgatan 20  
171 64 Stockholm | Fax +46 (0)8-703060  
[www.crealux.se](http://www.crealux.se)



Box 70396 | 10724 STOCKHOLM | SWEDEN  
Klarabergsviadukten 70  
Tel +46 (0)8-103070 | Fax +46 (0)8-103060  
info@crealux.se | www.crealux.se

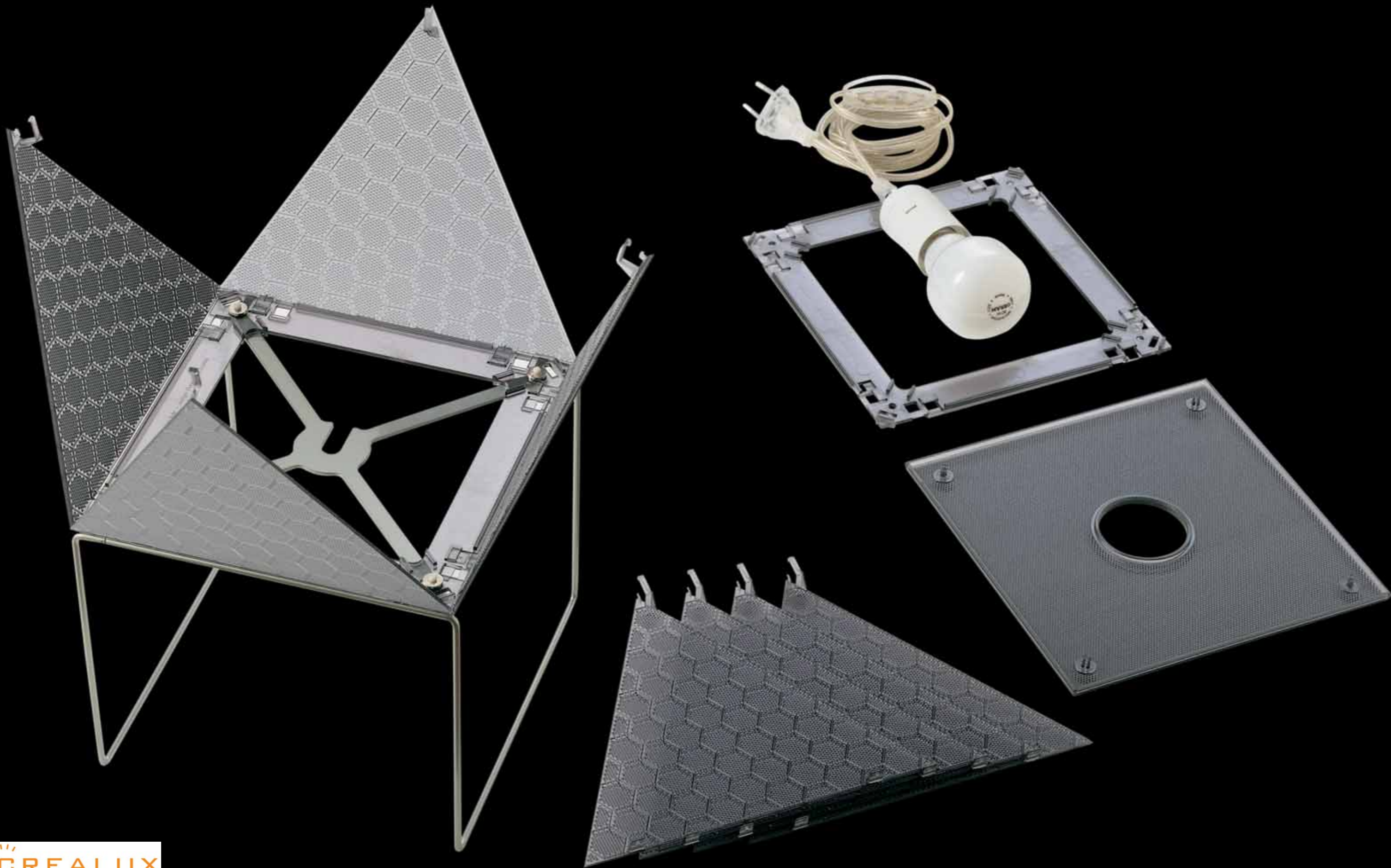

Box 70396 | 10724 STOCKHOLM | SWEDEN  
Klarabergsviadukten 70  
Tel +46 (0)8-103070 | Fax +46 (0)8-103060  
info@crealux.se | www.crealux.se

# EyeBall

design Jae Kyu Lee, 2004



trasparente fluo  
fluo transparent



blu fluo  
fluo blue



arancione fluo  
fluo orange

Lampada a sospensione o da tavolo/terra.  
La forma plastica della lampada nasce dall'articolazione di una superficie continua, che fa sembrare la lampada sempre diversa a seconda dei punti di vista.  
Diffusore in opalino incamiciato, soffiato a bocca, con finitura esterna acidata. Supporto del diffusore in policarbonato stampato ad iniezione. Cavalletto in tondino metallico per la versione d'appoggio. Cavo di alimentazione trasparente. Rosone in policarbonato stampato ad iniezione.

*Hanging and floor/table lamps.  
The plasticity of the form of the lamp is born out of the flowing external surface which seems to suggest that the lamp is for ever changing, depending on the viewing angle.  
Diffuser consisting of an externally etched, hand-blown, flashed opaline glass.  
Injection moulded, polycarbonate diffuser support. Transparent power cord.  
Opal polycarbonate injection moulded wall-rose.*

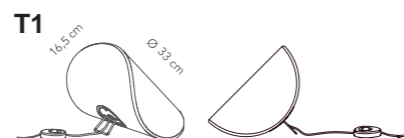
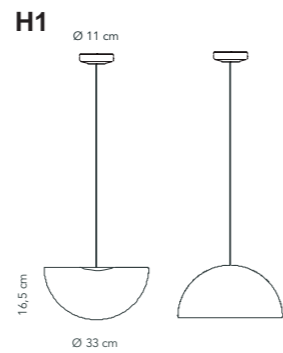
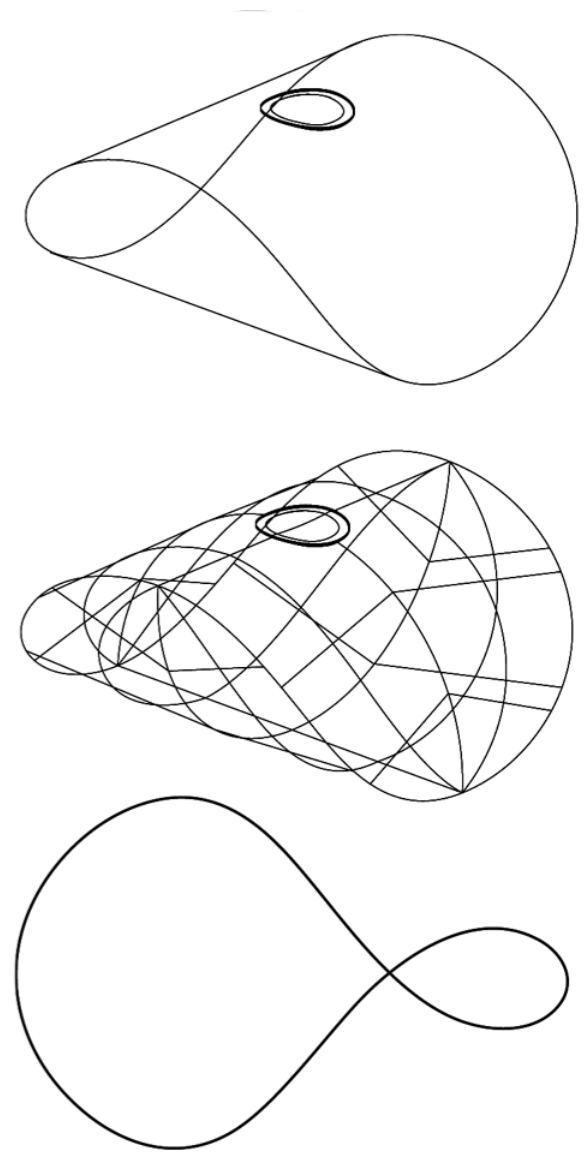



Box 70396 | 10724 STOCKHOLM | SWEDEN  
Klarabergsviadukten 70  
Tel +46 (0)8-103070 | Fax +46 (0)8-103060  
info@crealux.se | www.crealux.se



Box 70396 | 10724 STOCKHOLM | SWEDEN  
Klarabergsviadukten 70  
Tel +46 (0)8-103070 | Fax +46 (0)8-103060  
info@crealux.se | www.crealux.se

# Ipe

design Dante Donegani & Giovanni Lauda, 2004



cromo  
chrome



argento  
silver



nero satinato  
satin black

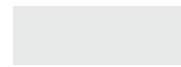

bianco satinato  
satin white



champagne

Lampada da parete a luce diretta ed indiretta, utilizza una sorgente alogena.

La sezione dell'apparecchio è simile ai profili metallici usati in architettura, da cui il nome della lampada.

La forma, originale ma discreta, le dimensioni ridotte e la facilità di montaggio a muro ne rendono estremamente duttile l'utilizzo in qualsiasi tipo di ambiente.

Struttura in lega di alluminio pressofuso, lucidato, cromato o finito con vernici a liquido ad alta temperatura.

*This wall lamp fixture, incorporating both direct and indirect light, has a halogen light source.*

*A section taken through the appliance shows the sort of metal profile commonly used by architect, and from which the unit takes its name. The shape, original but not elaborate, its modest dimension, and the ease of mounting on the wall makes for an extremely flexible utilisation in any type of environment. Die-cast aluminium body, polished and chromed or painted with high temperature varnish.*



 CREALUX

Box 70306 Rindögatan 100 SE-171 0524 STOCKHOLM | SWEDEN  
Klarabergsviadukten 70  
Tel +46 (0)8-103070 | Fax +46 (0)8-103060  
info@crealux.se | www.crealux.se



Box 70396 | 10724 STOCKHOLM | SWEDEN  
Klarabergsviadukten 70  
Tel +46 (0)8-103070 | Fax +46 (0)8-103060  
info@crealux.se | www.crealux.se



# Lisca

design Dante Donegani & Giovanni Lauda, 2003



diffusore bianco  
white diffuser



diffusore verde  
green diffuser



diffusore rosso  
red diffuser



diffusore giallo  
yellow diffuser



diffusore blu  
blue diffuser



diffusore specchiato  
mirrored diffuser

Lampade a sospensione.  
Struttura in alluminio estruso anodizzato.  
Diffusore composto da elementi verticali in policarbonato opale stampato ad iniezione e da elementi orizzontali in policarbonato opale fustellato.  
3 tipi di elettronica:  
standard, con dimmerazione dell'apparecchio mediante potenziometro sull'apparecchio, dimmerazione "DALI" a pulsante. Lisca ha vinto un iF product design award nel 2005.

*Hanging lamps.  
Anodized extruded aluminium structure.  
Diffuser made from opal polycarbonate injection-molded vertical elements, and die-cut horizontal opal polycarbonate reflectors.  
3 electronic versions:  
standard, dimmable by means of a potentiometer on the lamp, "DALI" ballast with dimmer operated by a push button.  
Lisca has won the iF product design award in 2005.*

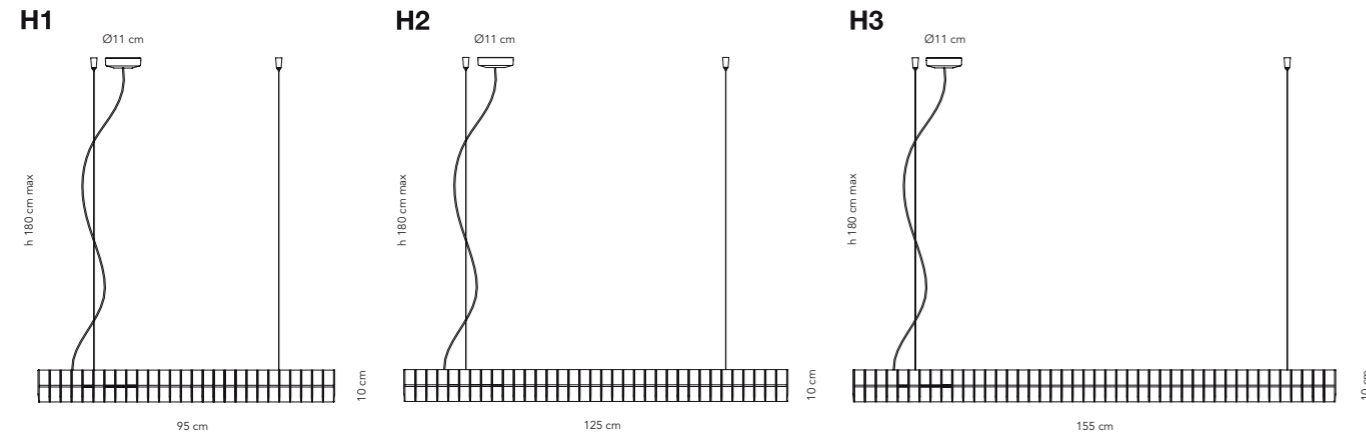

**H1**  
2 x G5 T16 (T5) 21W o 39W

**H2**  
2 x G5 T16 (T5) 29W o 54W

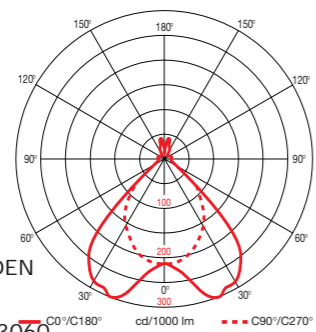

**LISCA AD EMISSIONE DI LUCE "DARK LIGHT"**  
Elementi ottici lamellari realizzati in ABS stampato ad iniezione e cromati (UL-94 HB). Diffusori laterali in policarbonato specchiato e serigrafato argento. Tappi laterali di chiusura realizzati in ABS stampato ad iniezione (UL-94 HB) e cromati. Nelle versioni H1, H2 e H3 gli apparecchi sono completi di set per la sospensione e regolazione, cavo di alimentazione e rosone.

**LISCA WITH DARK LIGHT**  
Laminar optical elements made in chromed injection-molded ABS (UL-94 HB). Lateral diffusers in mirrored polycarbonate, silkscreen processed in silver. Lateral sealing caps realized in injection-molded, chromed ABS (UL-94 HB). In H1, H2 and H3 versions the fixtures are provided with a kit for ceiling suspension and adjustment, complete with supply cable and rose.



Box 70396 | 10724 STOCKHOLM | SWEDEN  
Klarabergsviadukten 70  
Tel +46 (0)8-103070 | Fax +46 (0)8-103060  
info@crealux.se | www.crealux.se



**CREALUX**

Box 70396 | 10724 STOCKHOLM | SWEDEN  
Klarabergsviadukten 70  
Tel +46 (0)8-103070 | Fax +46 (0)8-103060  
info@crealux.se | www.crealux.se

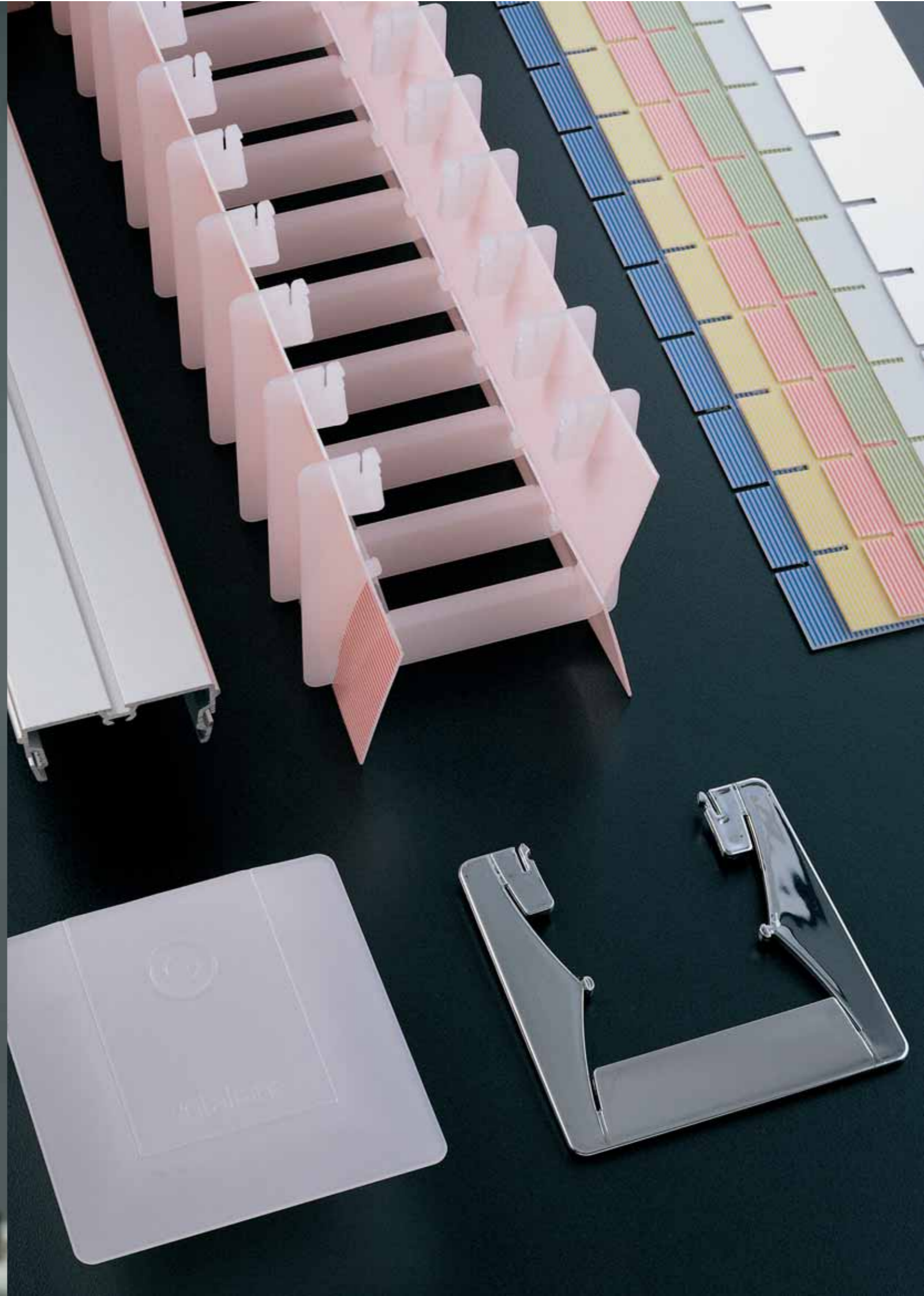

Box 70396 | 10724 STOCKHOLM | SWEDEN  
Klarabergsviadukten 70  
Tel +46 (0)8-103070 | Fax +46 (0)8-103060  
info@crealux.se | www.crealux.se

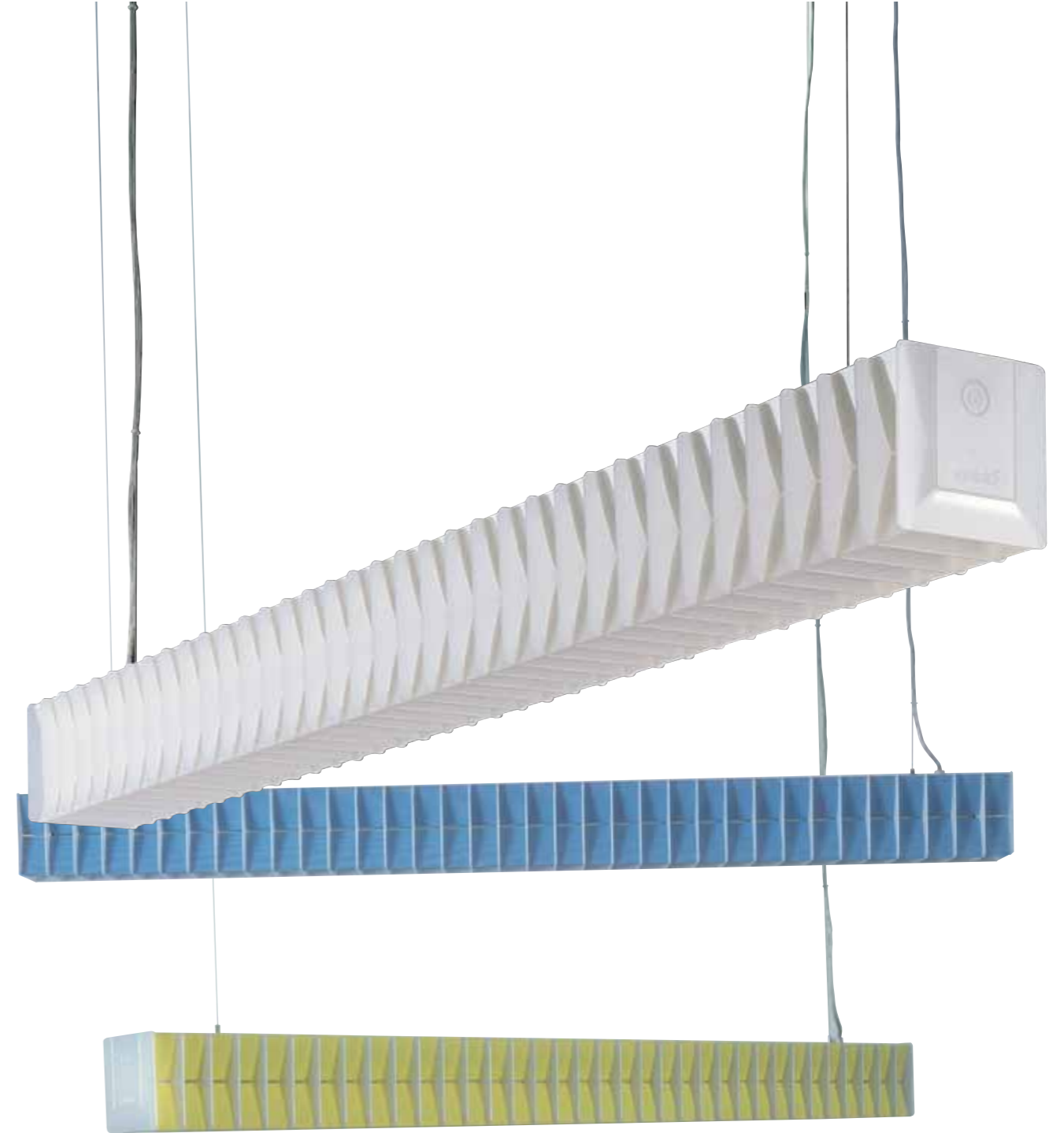

The logo for CREALUX, featuring the brand name in a bold, sans-serif font with a stylized sunburst icon to the left.

Box 70396 | 10724 STOCKHOLM | SWEDEN  
Klarabergsviaduktionen 70  
Tel +46 (0)8-103070 | Fax +46 (0)8-103060  
info@crealux.se | www.crealux.se

# Drink

design Dante Donegani & Giovanni Lauda, 2004

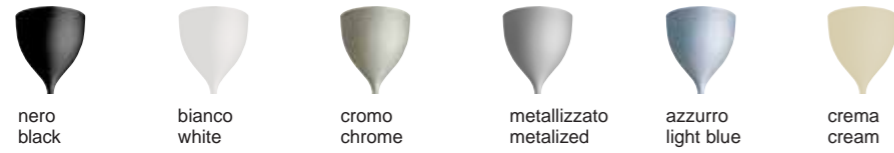

È una famiglia di lampade da terra, parete e sospensione. Il suo disegno, semplice ed iconico, ricorda la forma di un calice, colmo di luce. La struttura è in metallo cromato o verniciato. Nella versione da terra nello stelo è integrato il pulsante di dimmerazione, realizzato in policarbonato trasparente stampato ad iniezione. Drink è una famiglia di lampade che, per le dimensioni discrete e la forma essenziale, sono adatte a qualsiasi tipo di ambiente.

*Family of floor, wall and suspension lamps. Its design, simple and iconic, suggests a chalice shape, filled of light. The structure is in chromed or painted metal. An injection-moulded transparent polycarbonate push-button integrated into the stem, controls the light dimmer. Because of its accommodating dimensions, its simple form, Drink represents the essence of quality, suitable to be used in any environment.*

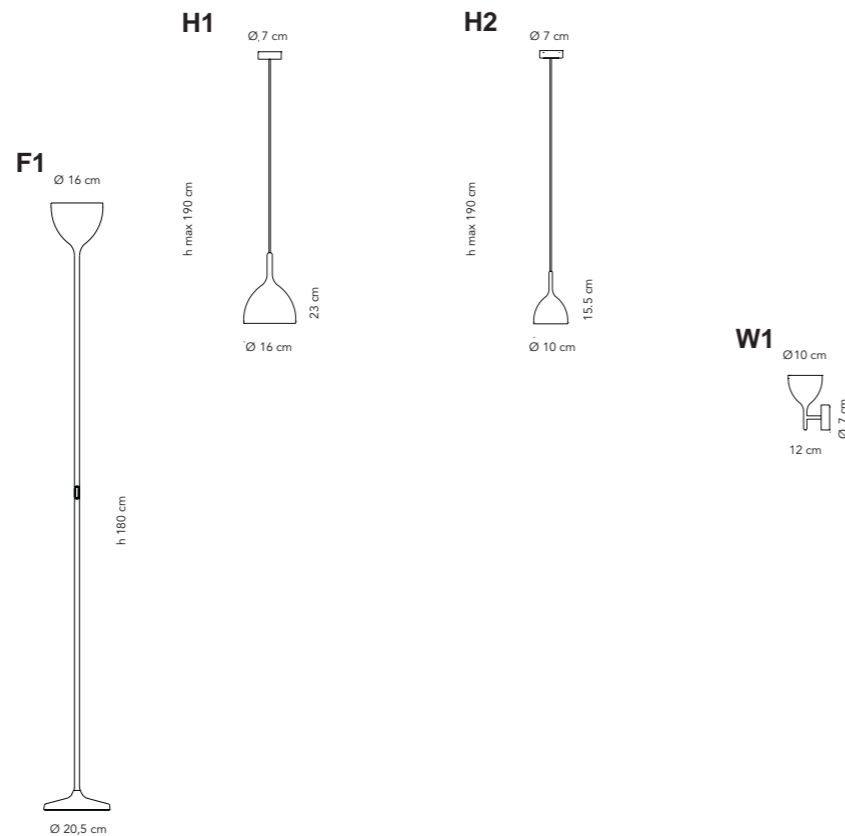

**F1**  
1 x E27 250W - QT32  
con dimmer a pulsante  
with push-button dimmer

**H1**  
1 x E27 100W - A60

**H2**  
**CREALUX**

**W1**  
Box 70376 | 10724 STOCKHOLM | SWEDEN  
1 x E9 75W - QT 14/m  
Klarabergsviadukten 70  
Tel +46 (0)8-103070 | Fax +46 (0)8-103060  
info@crealux.se | www.crealux.se

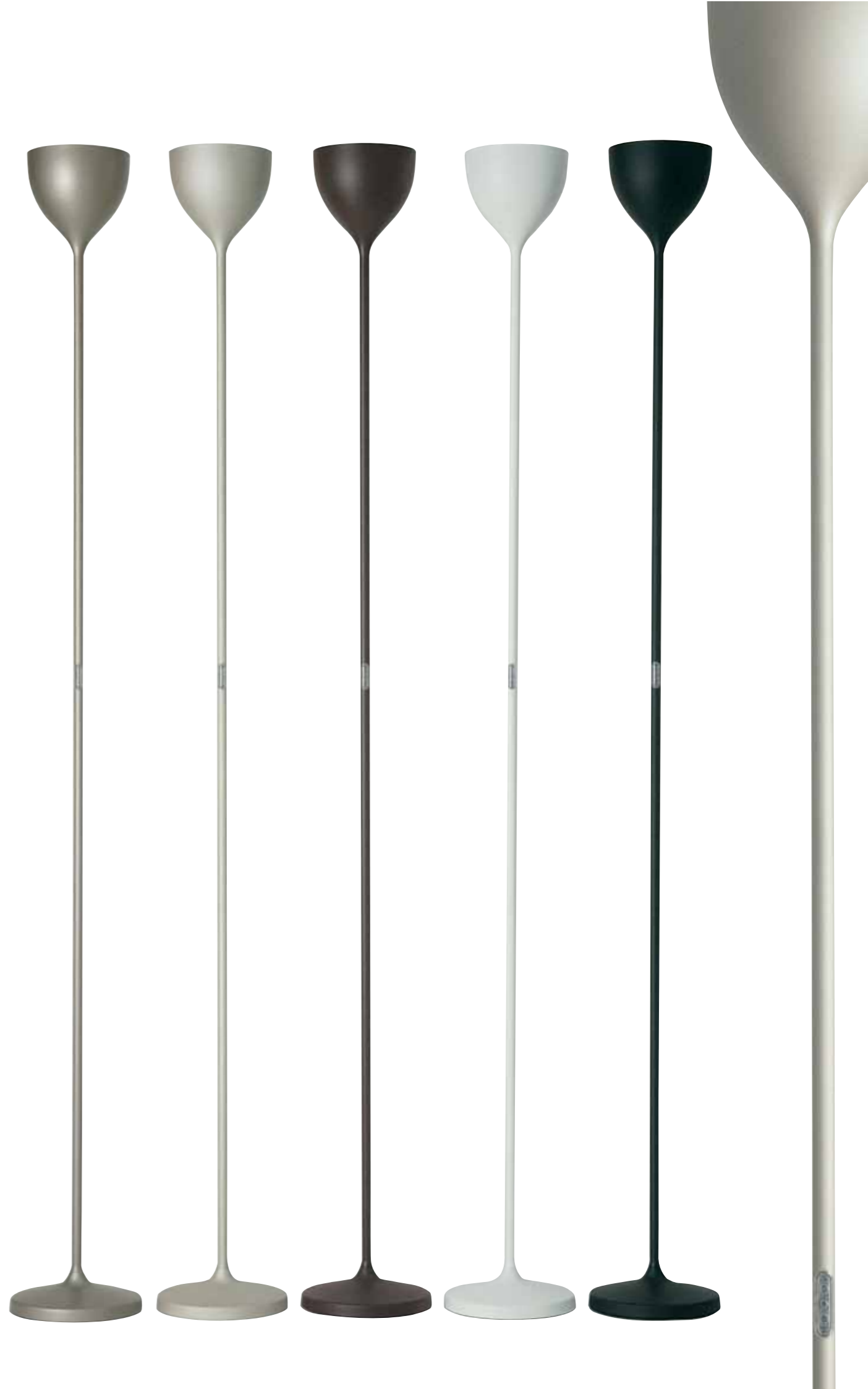

**CREALUX**

Box 70396 | 16124 STOCKHOLM | SWEDEN  
Klarabergsvägen 70  
Tel +46 (0)8-103070 | Fax +46 (0)8-103060  
info@crealux.se | www.crealux.se



Box 70396 | 10721 STOCKHOLM | SWEDEN  
Klarabergsviadukten 70  
Tel +46 (0)8-103070 | Fax +46 (0)8-103060  
info@crealux.se | www.crealux.se

# Lightwire

design Dante Donegani & Giovanni Lauda, 2003



È una lampada da terra a luce indiretta, in tondino di ferro elettrosaldato, leggera e trasparente. Gli elementi tecnici (il riflettore, il dimmer/interruttore e il disco tendi-cavo) sono indipendenti dalla struttura e, visivamente, galleggiano dentro di questa. Il filtro diicroico inserito nel riflettore conduce un fascio di luce colorata all'interno della lampada. Il dimmer/interruttore sensoriale con un led notturno, posto al centro della lampada, è realizzato in polycarbonato e acciaio; il disco tendi-cavo, montato ad incastro nell'anello della base, è in policarbonato. Il corpo della lampada è cromato oppure verniciato bianco o metallizzato.

*The Lightwire is a nimble transparent floor lamp providing indirect illumination. It is built using electrically welded steel rod.*  
*The technical components (reflector, dimmer/switch and disc-shaped cord reel) are independent from the frame and appear to be floating inside it.*  
*The filter inside the reflector directs a beam of coloured light toward the inside of the lamp.*  
*The touch-sensitive dimmer/switch with night-light LED and the disc-shaped cord reel (which is fitted into the base ring) are made of polycarbonate.*  
*The body of the lamp may be finished in chrome and in white or metalized enamel.*

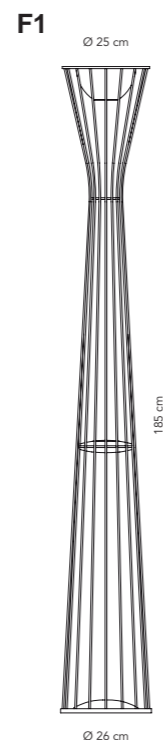

 CREALUX

Box 7036 Rindögatan 70  
Klarabergsviaduktens 70  
Tel +46 (0)8-103070 | Fax +46 (0)8-103060  
info@crealux.se | www.crealux.se

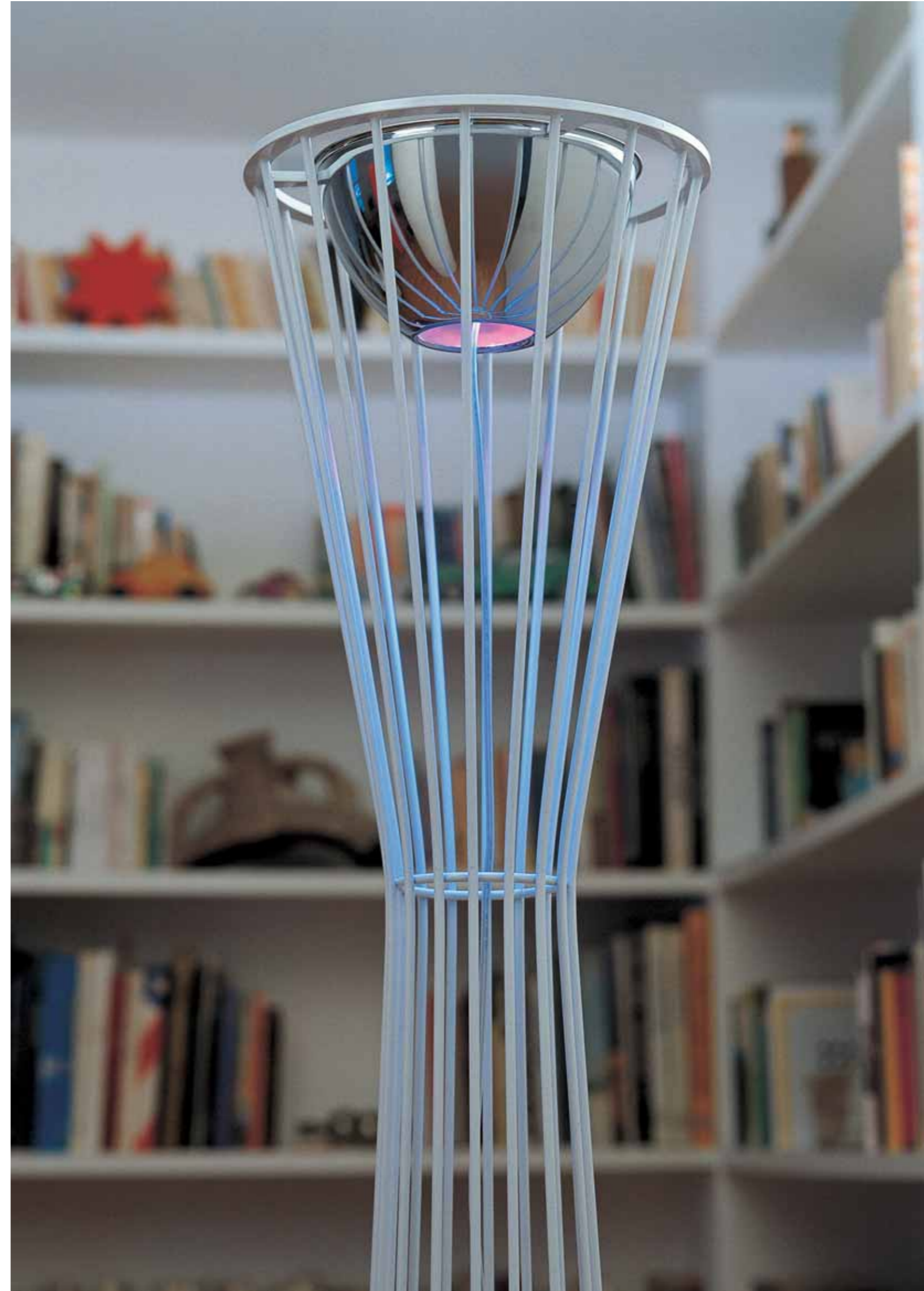



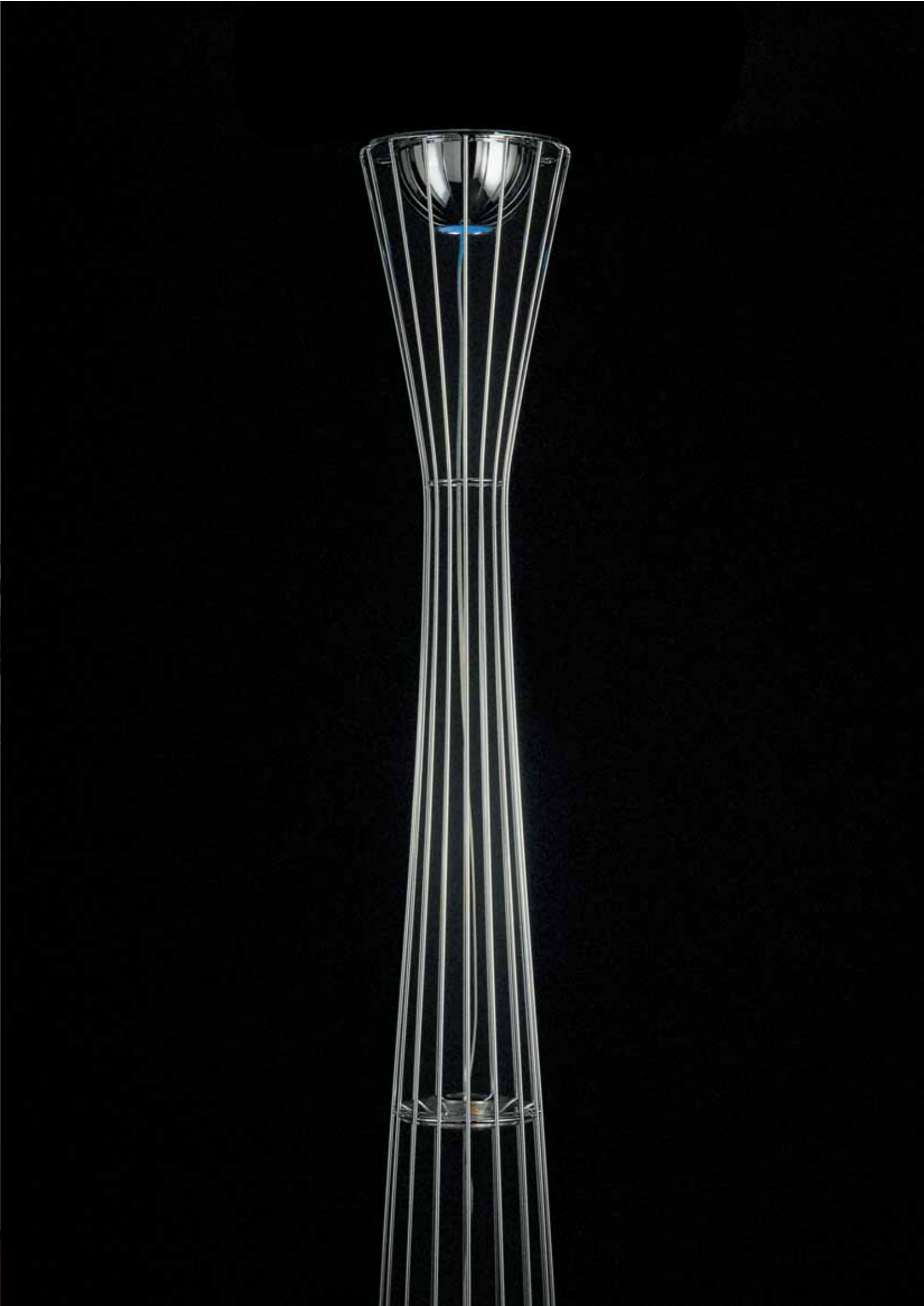

Box 70396 | 10724 STOCKHOLM | SWEDEN  
Klarabergsviadukt 70  
Tel +46 (0)8-103070 | Fax +46 (0)8-103060  
info@crealux.se | www.crealux.se

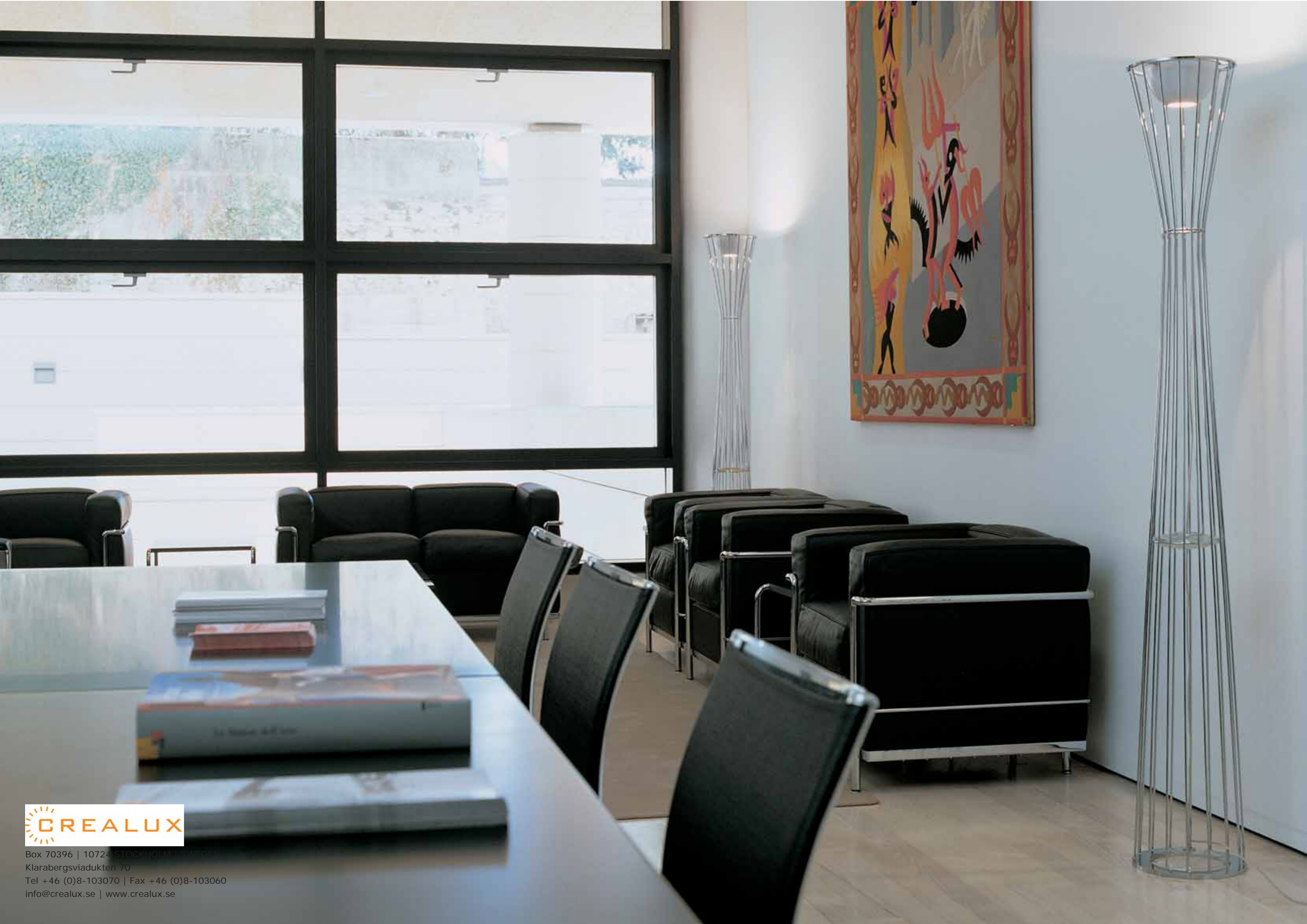

Box 70396 | 10724 STOCKHOLM | SWEDEN  
Klarabergsviadukten 70  
Tel +46 (0)8-103070 | Fax +46 (0)8-103060  
info@crealux.se | www.crealux.se

# Goccia

design Andrea Branzi, 2003

Lampada da sospensione a luce diffusa.  
La sua forma richiama quella di una goccia o di un gioiello pendente. Proposta in due dimensioni, la lampada ed il suo rosone sono realizzati interamente in vetro.  
Diffusore in vetro opalino incamiciato, lucido o satinato, soffiato a bocca. Struttura interna in metallo cromato.

*A suspended lamp offering soft illumination.  
Its shape recalls a drop of water or a jewellery pendant.  
Available in two sizes, the lamp and its rosette are created in blown glass.  
Diffuser consisting of a hand-blown, flashed opaline glass, glossy or etched. Inside structure in chromed metal.*

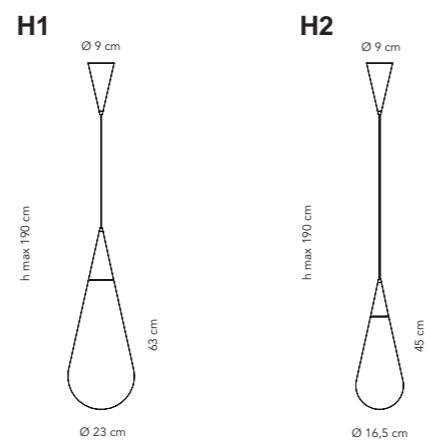



Box 103, SE-10724 STOCKHOLM | SWEDEN  
Kungälvavägen 70  
SE-418 00 Kungälv | Fax +46 (0)8-103060  
info@crealux.se | www.crealux.se

# Conca

design Dante Donegani & Giovanni Lauda, 2003



filtro blu  
blue filter

filtro verde  
green filter



filtro giallo  
yellow filter

filtro rosso  
red filter

E' una lampada da parete-soffitto realizzata in due misure. Utilizza, come sorgenti luminose, fluorescenti circolari compatte che garantiscono il risparmio energetico e un'alta resa luminosa. La forma concava del diffusore in vetro soffiato richiama quella di un piatto montato sulla parete. Nella lampada accesa, il filtro rimovibile colora il muro e il bordo esterno del diffusore. Diffusore in vetro opalino incamiciato, soffiato a bocca, lucido e satinato.

*Conca is a wall/ceiling lamp that is created in two sizes. Its compact circular fluorescent lamps use little energy, yet provide a great deal of light. The concave diffuser recalls the shape of a plate mounted on the wall. When the lamp is lit, a removable filter colours the wall and the outer edge of the diffuser. Diffuser consisting of an hand-blown, glossy or etched or opaline glass.*



W1

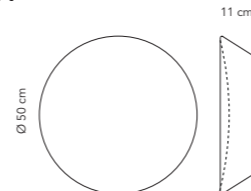

W2

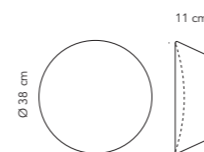

W1

2003010101 - 2003010101 - T16-R



Box 70396, 214 09 24 STOC  
Klarabergsvägen 70  
Tel +46 (0)8-103070 | Fax +46 (0)8-103060  
info@crealux.se | www.crealux.se

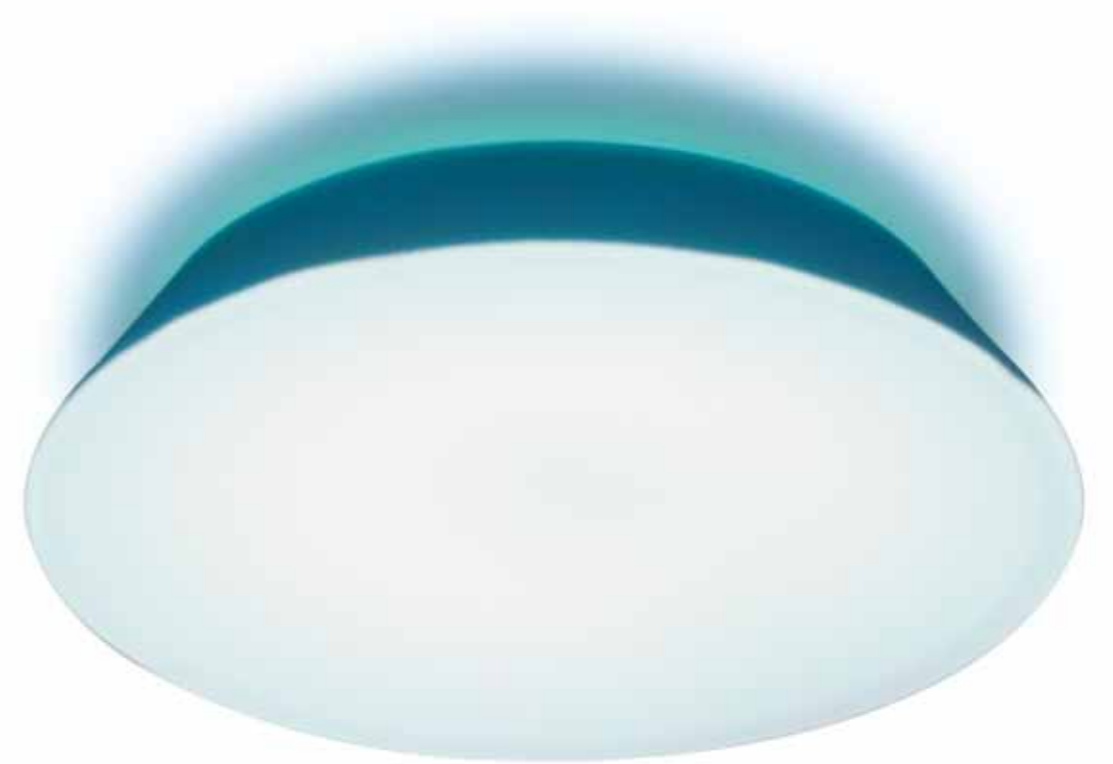

Box 70396 | 10724 STOCKHOLM | SWEDEN  
Klarabergsviadukten 70  
Tel +46 (0)8-103070 | Fax +46 (0)8-103060  
info@crealux.se | www.crealux.se

# Luxy

design Dante Donegani & Giovanni Lauda, 2002



bianco lucido  
bright white



bianco opaco  
etched white



metallizzato  
metalized



rosso lucido  
bright red



giallo lucido  
bright yellow



blu lucido  
bright blue



blu trasparente  
transparente blue

La famiglia comprende i modelli da tavolo, da terra, da parete, il faretto da soffitto e parete.  
Diffusori in vetro pressato. Forcelle e giunti in nylon rinforzato con il 50% di fibra di vetro stampati ad iniezione e verniciati. Snodi interni in ottone tornito e molle in acciaio. La maniglia è in microfusione d'acciaio. Tubo in acciaio verniciato a liquido. Copribase in acciaio verniciato. Base in lega di zama fusa a terra. Rosone in nylon rinforzato con il 50% di fibra di vetro stampati ad iniezione e verniciati. Interruttore ON-OFF posto sul diffusore, per tutti i modelli.  
Colore struttura in nero, bianco, metallizzato.

The family includes models for table, floor, wall, ceiling and wall spots.  
Pressed glass diffusers. Forks and joints with 50% fiberglass reinforced, injection-molded nylon.  
Cast steel grip. Brass turned swivel parts and steel springs.  
Varnished steel arms.  
Spun steel base cover, polished and varnished.  
Varnished wall/ceiling rose with 50% fiberglass reinforced, injection-molded nylon. ON-OFF switch for all models placed on the diffuser.  
Structure in black, white, silver.

H0

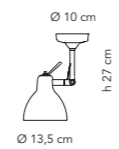

H1

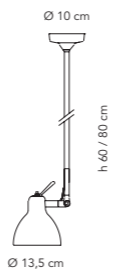

W0



W1

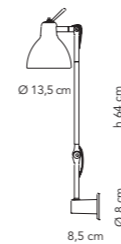

F1



W2



T1

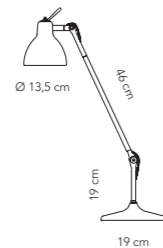

T2

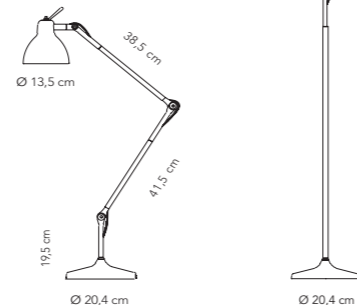

**CREALUX**

Box 70396 F-110924 B-15  
Klarabergsviadukten 70  
Tel +46 (0)8-103070 | Fax +46 (0)8-103060  
info@crealux.se | www.crealux.se





Box 70396 | 10724 STOCKHOLM | SWEDEN  
Klarabergsviadukten 70  
Tel +46 (0)8-103070 | Fax +46 (0)8-103060  
info@crealux.se | www.crealux.se





Box 70396 | 10724 STOCKHOLM | SWEDEN  
Klarabergsviadukten 70  
Tel +46 (0)8-103070 | Fax +46 (0)8-103060  
info@crealux.se | www.crealux.se



CREALUX

Box 70396 | 10724 STOCKHOLM | SWEDEN  
Marabergsvärdyken 70  
Tel +46 (0)8 103070 | Fax +46 (0)8 103060  
Info@crealux.se | www.crealux.se



# Officina

design Dante Donegani & Giovanni Lauda, 2002



bianco satinato  
etched white

metallizzato  
metalized

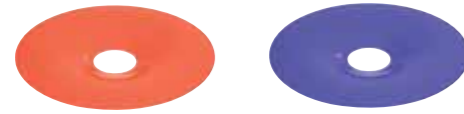

rosso lucido  
bright red

blu lucido  
bright blue

È una lampada a sospensione che riprende il disegno di un archetipo: l'apparecchio tecnico in metallo smaltato tipico dei locali di lavoro.

Officina è realizzata in due parti interamente in vetro. Per garantire una doppia illuminazione (diffusa e diretta) utilizza due sorgenti luminose: un fluorescente ad alto rendimento ed una dicroica che crea un fascio di luce concentrato verso il basso.

L'interruttore a rotazione posto sul fondo della lampada consente di azionare separatamente la luce diretta.

Il disegno classico, il tipo di illuminazione e la colorazione del vetro la rendono indicata sia ad un utilizzo domestico che nei locali pubblici quali ristoranti, bar.

*This is a hanging lamp that takes its design from an archetype: the sort of technical equipment with an enamelled metal finish typical of a working environment.*

*Officina is made in two sections designed entirely in glass. To ensure a double light effect (diffused and direct) two sources of luminosity are involved, one a high-output fluorescent bulb and the other a dichroic producing a downward directed flow.*

*A ball switch built into the bottom section allows the light to be directed at will. The combination of classic design, type of illumination offered and the colouring of the glass makes this a lamp suitable for use either in a domestic or a public (bars or restaurants) environment.*

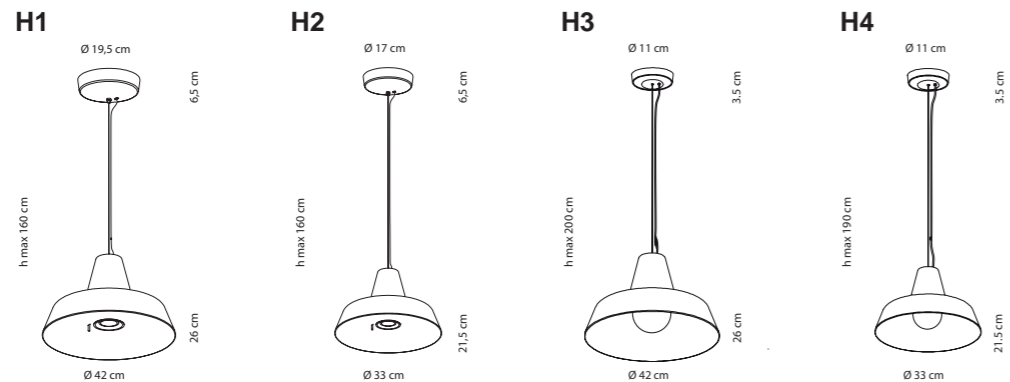

**H1**  
1 x 2GX13 40W - T16-R + 1 x GU10 75W - QPAR 50°



**H2**  
1 x 2GX13 22W - T16-R + 1 x GU10 75W - QPAR 50°

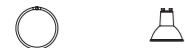

**H3**  
1 x GU10 75W - QPAR 50°



**CREALUX**

Box 70304 171 0924 995 STOCKHOLM | SWEDEN  
Klarabergsviadukten 70  
Tel +46 (0)8-103070 | Fax +46 (0)8-103060  
info@crealux.se | www.crealux.se





10724 STOCKHOLM | SWEDEN  
Tel +46 (0)8-103070 | Fax +46 (0)8-103068  
info@crealux.se | www.crealux.se



Box 70396 | 10724 STOCKHOLM | SWEDEN  
Klarabergsviadukten 70  
Tel +46 (0)8-103070 | Fax +46 (0)8-103060  
info@crealux.se | www.crealux.se

# Artica

design Burkhard Panteleit, 2002



filtro blu  
blue filter



filtro rosso  
red filter



filtro verde  
green filter

E' una sospensione a doppia emissione, che distribuisce rispettivamente luce diffusa, generata da tre lampadine da 60 W e diretta verso l'alto, utilizzando una sorgente alogena da 75 W max. E' realizzata in vetro con finitura bianco latte. Grazie alla quasi assenza di struttura, Artica si colloca con leggerezza e carattere in qualsiasi ambiente domestico o di lavoro. Con l'inserimento di un vetro colorato nella parte superiore della lampada, si possono ottenere degli effetti di luce colorata per personalizzare e decorare l'ambiente. Un interruttore a tre posizioni, posto sul fondo della lampada, seleziona le sorgenti luminose.

*This is a hanging model with a double luminous outflow which distributes either a diffused light - generated by three 60 W upwardpointing using a 75 W (max) halogen source. The lamp has been created in glass in a milk-white finish. Due to the almost total absence of any structural element Artica can fit with delicacy and character into any domestic or work environment. The use of a coloured glass in the upper section of the fixture will give a coloured light to personalise and give character to an environment. A switch with three options, located on the base of the lamp, controls the light sources.*

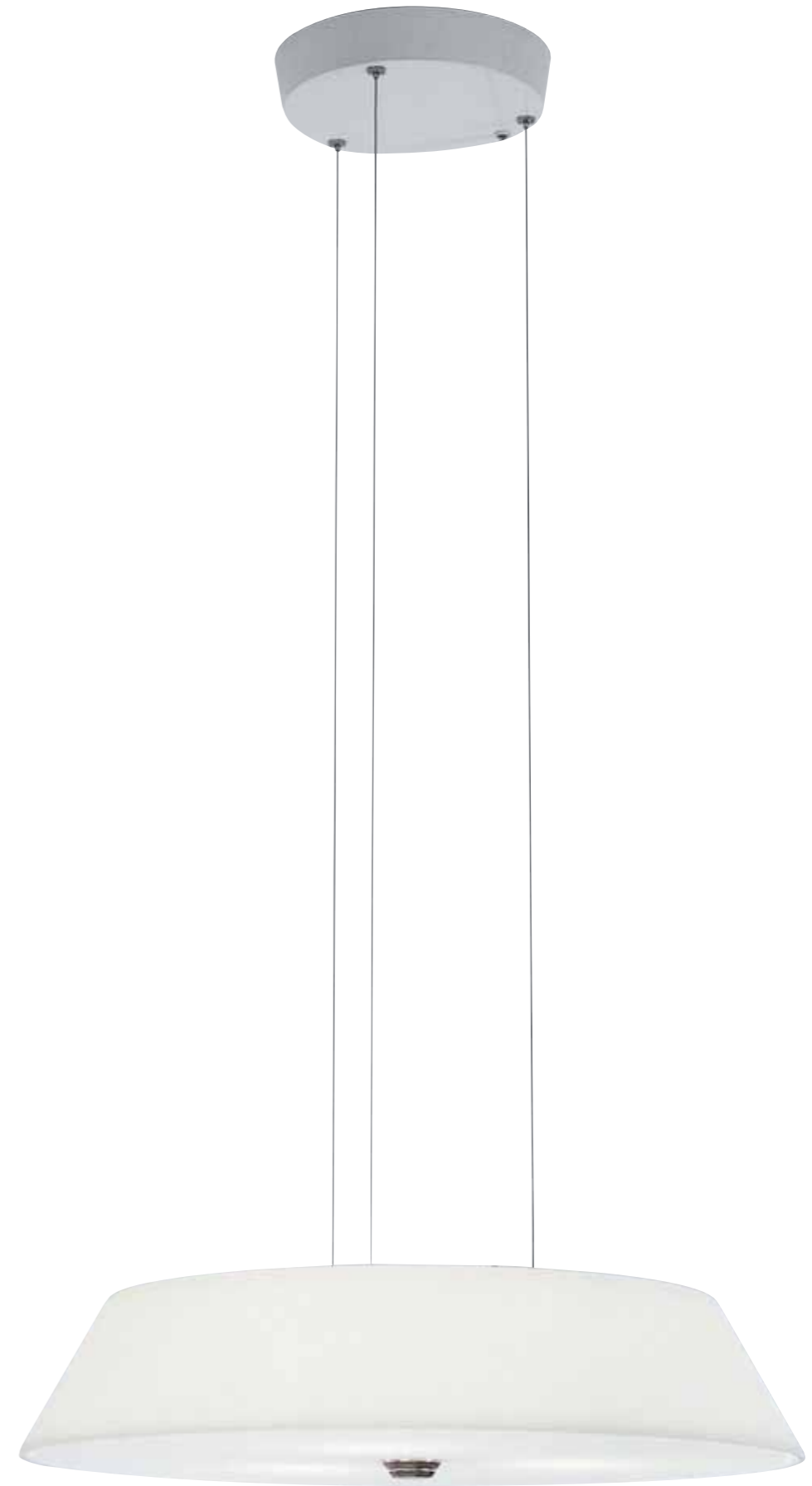
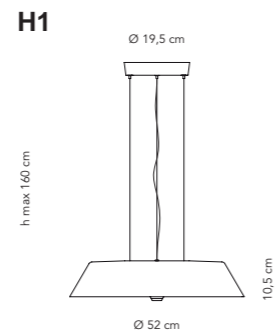

**CREALUX**

Box 70396 | GU 10 75W | PAR 50 | E 14 60W | G35  
Klarabergsviadukten 70  
Tel +46 (0)8-103070 | Fax +46 (0)8-103060  
info@crealux.se | www.crealux.se



Box 70396 | 10724 STOCKHOLM | SWEDEN  
Klarabergsviadukten 70  
Tel +46 (0)8-103070 | Fax +46 (0)8-103060  
info@crealux.se | www.crealux.se

# Bubble

design Burkhard Panteleit, 2001



vetro bianco satinato  
etched white glass



vetro bianco lucido  
bright white glass

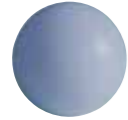

vetro azzurro lucido  
bright azure glass



vetro aragosta lucido  
bright lobster glass

È una famiglia di lampade da terra, sospensione, tavolo e parete dal disegno elegante e decorativo. Le lampade Bubble sono caratterizzate dai diffusori sferici in vetro soffiato bianco, aragosta e azzurro, inseriti dentro una cornice in tubolare metallico. Regolazione della luce con potenziometro sullo stelo.

*This family of lights, of elegant and decorative design, includes floor, hanging, table and wall models. Bubble lamps are identifiable by their spherical diffusers in individually blown glass forms of a white, azure and lobster colour, mounted within a tubular metal frame. Light control with potentiometer on the lamp stem.*

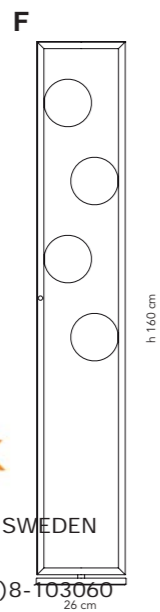

T2

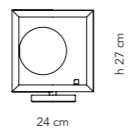

T1

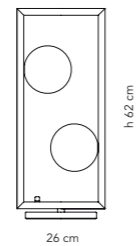

T

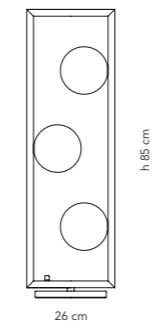

H

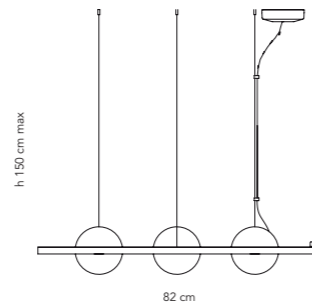

W

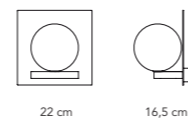

W1

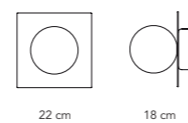

FHTT1  
CREALUX

Box 70398 | SE-171 45 STOCKHOLM | SWEDEN  
Klarabergsviadukten 70  
Tel +46 (0)8-103070 | Fax +46 (0)8-103060  
info@crealux.se | www.crealux.se





Box 70396 | 10724 STOCKHOLM | SWEDEN  
Klarabergsvägen 70  
Tel +46 (0)8-103070 | Fax +46 (0)8-103060  
info@crealux.se | www.crealux.se



Box 70396 | 10724 STOCKHOLM | SWEDEN  
Klarabergsviadukten 70  
Tel +46 (0)8-103070 | Fax +46 (0)8-103060  
info@crealux.se | www.crealux.se

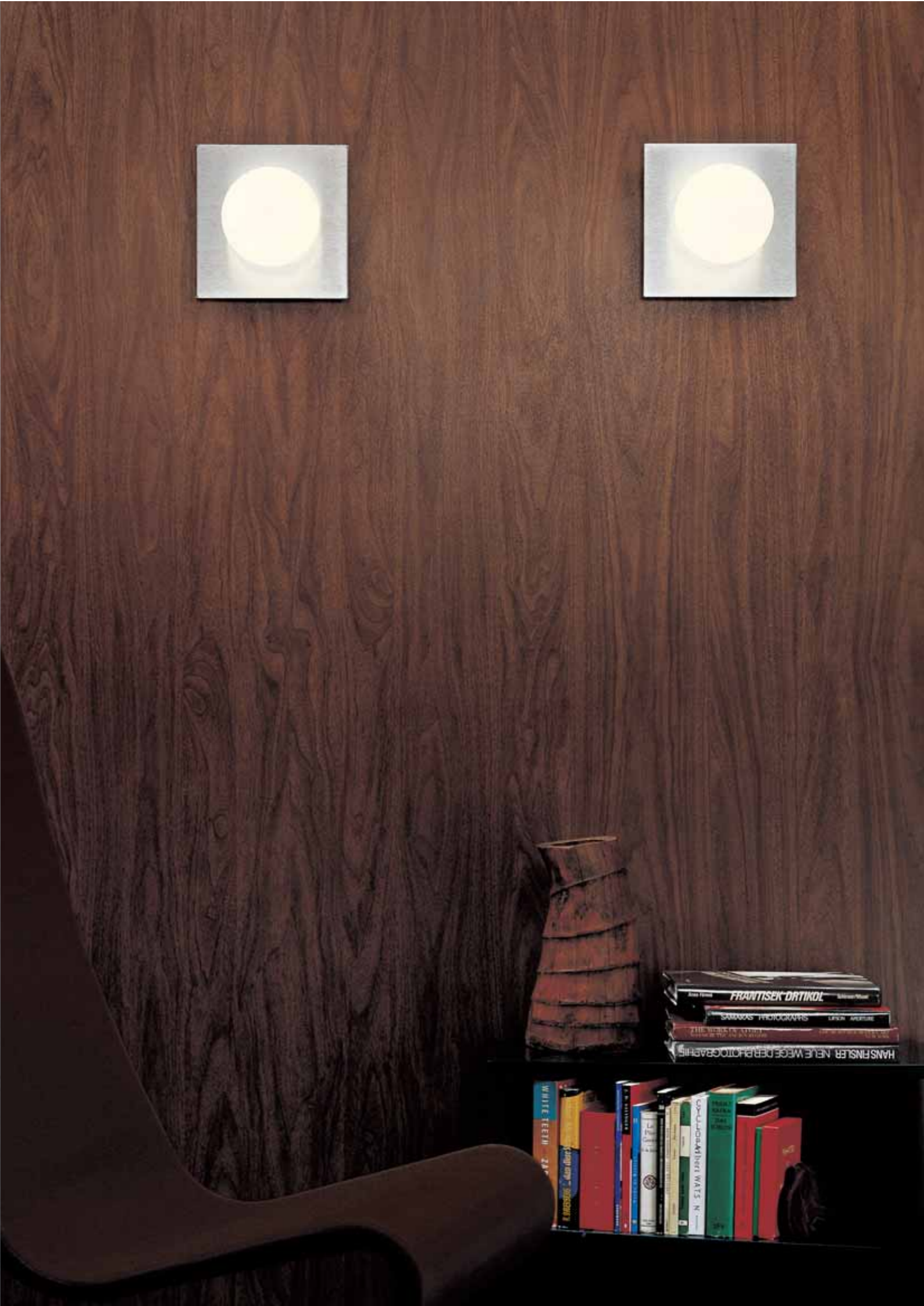

Box 70396 | 10724 STOCKHOLM | SWEDEN  
Kontakt: +46 (0)8-103060  
www.crealux.se



Andrea Branzi

**Andrea Branzi**, architetto e designer, nato a Firenze nel 1938, dove si è laureato nel 1967, vive e lavora a Milano. Dal 1964 al 1974 ha fatto parte del gruppo Archizoom Associati, primo gruppo di avanguardia noto in campo internazionale, i cui progetti sono oggi conservati presso il Centro Studi e Archivio della Comunicazione dell'Università di Parma e dal CCI del Centre Georges Pompidou di Parigi. Dal 1967 si occupa di design industriale e sperimentale, architettura, progettazione urbana, didattica e promozione culturale. È Docente di Disegno Industriale al Politecnico di Milano.

*Architect and designer **Andrea Branzi** was born in 1938 in Florence, where he earned a degree in 1967. He currently lives and works in Milan. From 1964 to 1974, he was part of the Archizoom Associati group, the first avant-garde design studio on the international scene, whose projects are now conserved by the University of Parma at its Study and Archive Centre for Communication and by CCI at the Georges Pompidou Centre in Paris. Since 1967, Andrea Branzi has been engaged in industrial and experimental design, architecture, urban design, teaching and cultural promotion. He is an instructor of industrial design at the Polytechnic Institute of Milan.*



Camilla Diedrich

**Camilla Diedrich**, è nata a Stoccolma, in una famiglia di artisti. Nel 2000 ha ricevuto il premio "Light idea of the year", indetto dalla rivista Sköna Hem, con un prototipo della lampada BPL. "Luminosità Straordinariamente Poetica" è stato il commento della giuria. Nel 2005 ha messo in mostra, presso Svensk Form di Stoccolma, una collezione di tessuti tridimensionali e soffici, prodotti da Sanden Textiles. Vive e lavora a Stoccolma.

***Camilla Diedrich**, born in Sthlm, Sweden, grew up in an artist home. On 2000 she received the award "Light Idea of the year" from the Swedish Magazine Sköna Hem for her bubbly lamp "BPL" "Tremendous Poetic Luminosity" the Jury stated On 2005 she had an exhibition at Svensk Form in Stockholm supported by The Arts Grants Committee where she showed her view on 3D textildesign used as soft walls, now in production by Sanden Textiles. Has her own studio in Stockholm.*



Dante Donegani

**Dante Donegani** è nato a Pinzolo (Trento) nel 1957 e si laurea in Architettura a Firenze nel 1983. Lavora dal 1987 al 1991 nella Corporate Identity Olivetti. Dal 1991 è Direttore del Master in Design di Domus Academy a Milano. Nel 1992 apre lo studio D&L con Giovanni Lauda. Progetta allestimenti di mostre d'arte, sistemi di identificazione aziendali e disegna prodotti per varie aziende tra cui Memphis, Stildomus, Isuzu, Steel e Luceplan, Le Cose Nostre, Edra, Radice e Viceversa. Ha vinto importanti concorsi d'Architettura e i suoi lavori sono stati esposti in numerose mostre; nel 2001 ha curato il settore casa della mostra "Italia e Giappone, Design come stile di vita".

*Born in Pinzolo (province of Trento) in 1957, **Dante Donegani** was awarded a degree in architecture in Florence in 1983. From 1987 to 1991, he worked in the Olivetti Corporate Identity department. Since 1991 he has been the director of the master's program in design at the Domus Academy in Milan. In 1992 he opened the D&L Studio together with Giovanni Lauda. He has designed layouts for art exhibitions, corporate identity projects, and products for a number of companies that include Memphis, Stildomus, Isuzu, Steel and Luceplan, Le Cose Nostre, Edra, Radice and Viceversa. Dante Donegani has won important competitions in architecture, and his work have been displayed in numerous exhibitions. In 2001, he was responsible for setting up the "home" section of the exhibition entitled "Italy and Japan: Design as Lifestyle".*



Toyo Ito

**Toyo Ito**. Nato nel 1941, nel 1971 ha fondato lo studio Toyo Ito & Associati. Tra i suoi lavori più importanti: White U(1976), Silver Hut (1984), Tower of Winds(1986), Shimosuwa Municipal Museum (1993), Dome in Odate (1997) and Sendai Mediatheque (2001). Recentemente sta lavorando anche a progetti oltreoceano e particolarmente in Europa. Ha realizzato il Bruges Pavilion (2002) e il Serpentine Gallery Pavillion 2002 a Londra (2002) e sta lavorando a molti progetti tra i quali Mahler 4 Block 5 ad Amsterdam, Hospital Cognacq-Jay a Paris, ed il Relaxation Park a Torre Vieja. Nel gennaio 2003 ha vinto il concorso per l'ampliamento della fiera di Barcellona: Monjuic-2. Nel 2002 la Biennale di Venezia gli ha conferito il Leone d'Oro alla carriera come riconoscimento al suo insigne contributo all'architettura contemporanea.

***Toyo Ito**. Born in 1941 and started Toyo Ito & Associates Architects in 1971. His main works include, White U(1976), Silver Hut(1984), Tower of Winds(1986), Shimosuwa Municipal Museum(1993), Dome in Odate(1997) and Sendai Mediatheque(2001). Recently not only at domestic projects, he is working at overseas projects particularly in Europe. He has made Bruges Pavilion(2002) and Serpentine Gallery Pavilion 2002 in London(2002) and now working on several projects including Mahler 4 Block 5 in Amsterdam, Hospital Cognacq-Jay in Paris, and Relaxation Park in Torre Vieja. In January 2003, he has won the competition for the expansion at Fair of Barcelona Fair: Monjuic - 2. At the Venice Biennale in 2002, he was awarded with the Golden Lion for Lifetime Achievement in recognition of his distinguished contribution to contemporary architecture.*



Giovanni Lauda

**Giovanni Lauda** è nato nel 1956 a Napoli, dove si laurea in Architettura. Ha fatto parte dal 1988 al 1991 dello studio Morozzi & Partners. Nel 1992 apre lo studio D&L con Dante Donegani. Ha realizzato prodotti nel settore domestico per Sedie & Company, Play line, Le Cose Nostre, Edra, Radice e Viceversa. Ha progettato arredi domestici e negozi, allestimenti di mostre e allestimenti commerciali. Ha collaborato alla cura della mostra "Il Design italiano 1964 - 1990" al palazzo della Triennale di Milano nel 1996 e della mostra "Italia e Giappone, Design come stile di vita" nel 2001. Dal 1993 svolge attività didattica alla Domus Academy di Milano.

***Giovanni Lauda** was born in 1956 in Naples, where he gained a degree in architecture, and was a member of the Morozzi & Partners studio from 1988 to 1991. In 1992, he opened the D&L Studio together with Dante Donegani. He created products in the home sector for Sedie & Company, Play line, Le Cose Nostre, Edra, Radice and Viceversa. Giovanni Lauda has designed furnishings for homes and stores, stagings for art exhibitions, and commercial layouts. In 1996, he participated in the creation of an exhibition entitled "Italian design from 1964 to 1990" at the Triennale of Milan, and contributed to an exhibition called "Italy and Japan: Design as Lifestyle" in 2001. He has been teaching at the Domus Academy in Milan since 1993.*



Jae Kyu Lee

**Jae Kyu Lee** è nato a Seul, in Corea nel 1964, dove si è diplomato in architettura. Dopo il master in design alla Domus Academy di Milano nel 1996, vive e lavora in Italia come architetto e designer. Uno dei suoi progetti di "transient office" è stato selezionato per la collezione permanente del M.O.M.A. di New York.

***Jae Kyu Lee** was born in Seul, Corea in 1964, where he gained a degree in architecture. After being awarded a master in design at Domus Academy in Milan in 1996, he lives and works in Italy as architect and designer. One of his projects of "transient office" has been selected for the permanent collection of M.O.M.A. in New York.*



Burkhard Panteleit

**Burkhard Panteleit** è nato a Berlino nel 1943 dove ha frequentato la scuola di apprendistato con indirizzo specifico alla produzione di apparecchi di illuminazione. Ha quindi frequentato l'Accademia delle Arti di Berlino. Dal 1971 lavora come designer, in particolare per le aziende di illuminazione.

***Burkhard Panteleit** was born in Berlin in 1943, and he attended an apprenticeship school where he specialised in lighting manufacture. He gained a degree at the Academy of Arts in Berlin. Since 1971 he has been working as a designer concentrating on the lighting industry.*



**elettrica rotaliana srl**

via della rupe 35  
38017 mezzolombardo (tn)  
italy

tel. +39.0461.602376  
fax +39.0461.602539  
info@rotaliana.it  
www.rotaliana.it

**Grazie a / Thanks to**

**Linda Gobbi e Francesco Morace**  
- Future Concept Lab -  
per il testo introduttivo  
for the introduction text

**Piazza Sempione Milano**

**MART**  
Museo di Arte moderna  
e contemporanea  
di Trento e Rovereto

**Photo**  
Emilio Tremolada

**Graphic design**  
LLewisGuiotto

**Fotolito**  
Pluscolor  
Bigraphic

**Stampa**  
Litografica Editrice Saturnia Trento



Box 70396 | 10724 STOCKHOLM | SWEDEN  
Klarabergsviadukten 70  
Tel +46 (0)8-103070 | Fax +46 (0)8-103060  
info@crealux.se | www.crealux.se

© Rotaliana 2005